

INFINITY[®]

MASSAGE CHAIRS



User Manual

**ZENARA™
MASSAGE CHAIR**

Welcome to

INFINITY

THE ULTIMATE MESSAGE EXPERIENCE

Thank you and congratulations on purchasing an Infinity Massage Chair - you've made a great choice.

With over a decade of experience designing, building and servicing massage chairs, Infinity takes pride in every chair sold, including yours. We are here for you. The US-based Customer Care team can be reached at (603) 910-5000 or visit us online at www.infinitymassagechairs.com and find valuable self service resources under the SUPPORT tab, including electronic copies of all documents and video tutorials.

Inside this manual, you will find everything you need to setup and safely enjoy your chair. Please review the entire manual, including all safety information, before assembling or using your chair. If you are assembling the chair yourself, please see the Assembly Guide next and reference the online assembly video.

For convenience, we've also created a Quick Start Guide. We suggest you keep it near the chair as a tool to get to know all the features of your new chair.

Get ready to sit back, relax and enjoy the Ultimate Massage Experience.

Warranty Registration

Register your product at www.infinitymassagechairs.com/warranty to ensure it is in our system. This will simplify the warranty process should you ever need it.

Alternatively, **scan the QR code** to go directly to the URL above.



SCAN CODE

Assembly Video

Before assembling your chair, watch an assembly video at: www.infinitymassagechairs.com/assembly-tutorials

Alternatively, **scan the QR code** to go directly to the URL above.



SCAN CODE

@infinitymassagechairs

@infinity_chairs

@infinitymassagechairs

We know you can't wait to sit in your new Infinity Massage chair! Take a picture of you enjoying the ultimate massage experience and make sure to tag us on social media with the hashtag [#infinitymassagechairs](https://www.instagram.com/explore/tags/infinitymassagechairs)

Table of Contents

Your Chair

Chair Features	4
External Structure	5

Before Getting Started

Installation Site	6
Clearance Space for the Chair	6
Floor Protection	6
Move Methods	7
Connect to Power	7

Chair Setup

Main Power Switch	8
Adjust Pillow	8
Increase Intensity of Massage – Manually	8
TrueFit® Body Scanning	8
Getting out of the Chair	9
Chair Entry and Exit Hazards	9

Taking Control

Tablet Style Controller	10
Tablet Style Controller Operations	11
Tablet Style Controller Display Screen	13

Set Your Environment

Auto Mode	14
Full Body	14
Focused	14
Deep Sleep	14
Gentle	14
All Air	15
Demo	15
Manual Mode	15
Manual Massage	15
Mechanism Width	15
Mechanism Speed	15
Whole	15
Partial	15
Point	15
Power/Play/Pause	16
Air Zone	16
Bluetooth/LED	16
Time	16
Air Intensity	16

Voice Broadcasting	16
Heating	16
Foot Roller	16
Zero Gravity	17
Back Up	17
Back Down	17
Roller Up	17
Roller Down	17

Staying Safe

Fixing Issues

Troubleshooting	21
Specifications	21
Frequently Asked Questions	22
Warranty	23



Warning! Read important safety information found on page 18 before using or operating chair.

Your Chair

Chair Features

TrueFit™
Body Scanning



See page 8

Tablet Style
Controller



See page 10

Manual Mode



See page 15

Airbag Control



See page 16

Lumbar
Heat



See page 16

Reflexology
Foot Roller



See page 16

Bluetooth® Speakers



See page 16

Chromotherapy
Lighting



See page 16

Weightless Zero
Gravity Recline



See page 17

External Structure

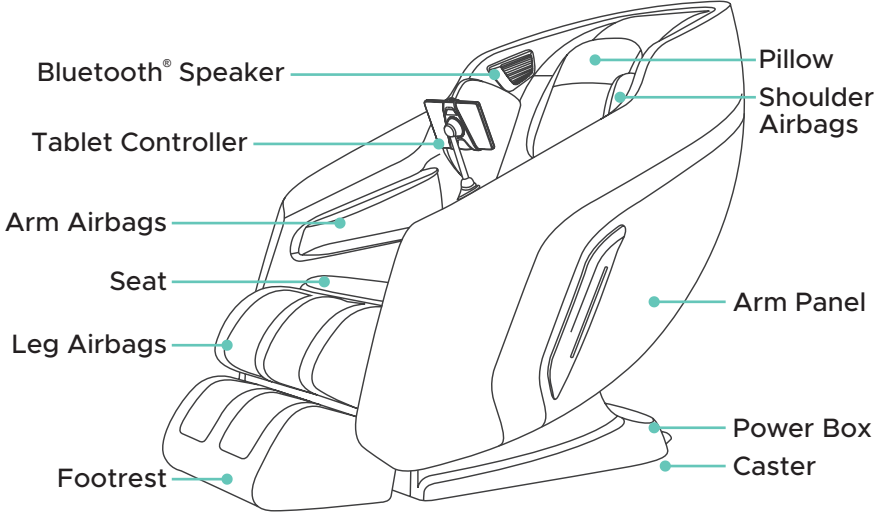

Before Getting Started

Installation Site

Clearance Space for the Chair

- 9.5" clearance for the recline of the backrest; 24" clearance for the extension of footrest and sliding forward of the chair.
- Keep it 3 feet away from the TV, radio or other audio & video appliance to avoid signal interference.

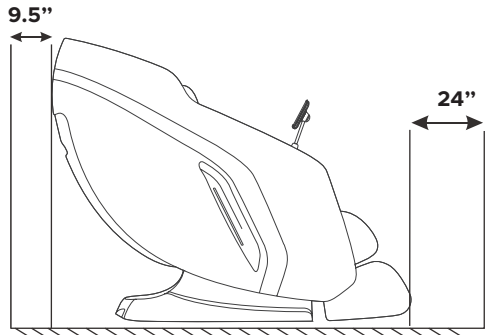

- Keep the distance between the power socket and power switch within 60" to avoid damage of power cord while massage chair sliding forward.
- Straighten the power cord while in use to avoid tangle or damage.



- To avoid serious injury or death, before sliding chair forward or backward check to make sure area is clear of children, pets, or obstacles.

Floor Protection

To protect ANY floor type, hard surface or carpeted, from scratches or other markings, place the chair on a pad or mat that extends from under the footrest to the rear of the chair.

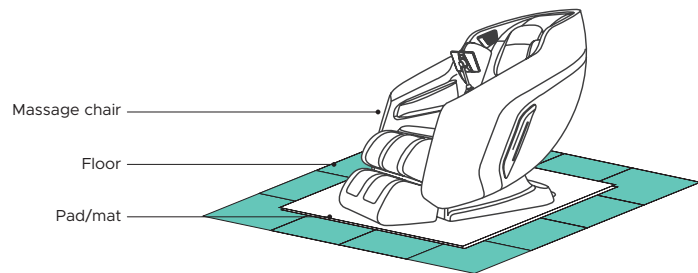

- Do not use the massage chair in high moisture environment such as near a swimming pool or bathroom to prevent electric shock accident.
- Please keep the massage chair away from heated surfaces to prevent fire hazard or damage to the product.

Move Methods

Apply pressure to the back of the massage chair from behind to pivot on the chair's casters. Have a second person up front guide the footrest until in the correct position. Maintain clearances as mentioned above. Gently lower into place. Do not push or pull on the side arms.

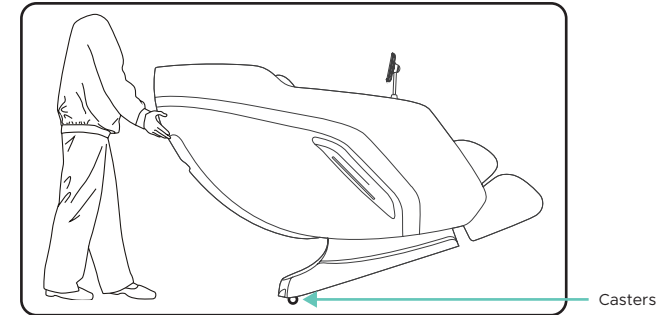

- Do not move the chair when there is a user inside.
- Chair is heavy. Use caution and get assistance when lifting to avoid injury. Do NOT lift chair by footrest or armrests to avoid damage to product.

Connect to Power

Plug into a 120V grounded outlet.



WARNING

Grounding Instructions

To avoid risk of electrical shock, turn power switch off before plugging unit into electrical outlet. Use only with properly grounded outlet (3 prong). Do not plug into ungrounded outlet.

WARNING – Improper connection of the equipment-grounding conductor can result in a risk of electric shock. Check with a qualified electrician or serviceman if you are in doubt as to whether the product is properly grounded. Do not modify the plug provided with the product – if it will not fit the outlet, have a proper outlet installed by a qualified electrician.

This product is for use on a nominal 120-V circuit and has a grounding plug that looks like the plug illustrated. Make sure that the product is connected to an outlet having the same configuration as the plug. No adapter should be used with this product.

Earthing

This massage chair is a Class 1 electrical appliance. Make sure to use a grounded outlet to the grounded power supply circuit and a properly installed earth grounding rod with ground connection, to avoid electric shock.

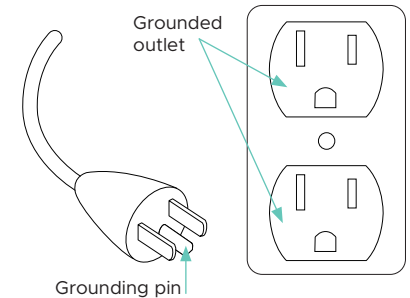

Chair Setup

Getting Comfortable

Main Power Switch

Plug the power cord into the power port on the back of the massage chair, then connect the other end to a grounded 120V outlet. Turn on the chair by switching the power button to “I” or “ON.”

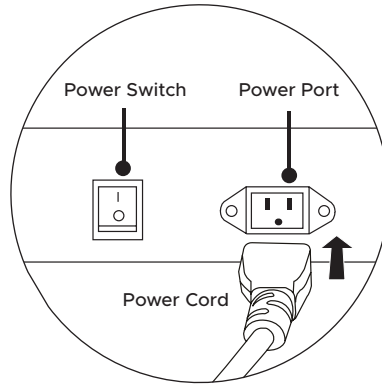

- To avoid possible damage to product or injury to unsupervised children, always turn off power switch and unplug massage chair from electrical outlet immediately after use.
- When not in use for a long period of time, we recommend that the chair be covered, the power cord be coiled and that the unit be placed in an environment free of dust and moisture.

Adjust Pillow

Take a seat in the chair and take note of where the pillow rests on your neck. Adjust the pillow so that it rests comfortably in the arch of your neck.

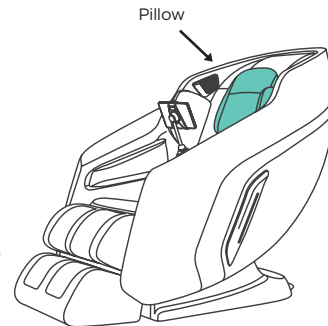

Increase Intensity of your Massage - Manually

To make the massage more intense, flip the **pillow** between you and the massage mechanism in the seat back. To remove the pillow, simply unzip the zippers and place aside the pillow.

TrueFit® Body Scanning

After starting any auto program or manual massage, the chair will automatically begin scanning your body, mapping your back, shoulders, and neck. During this process it is important to remain seated back into the chair without lifting your head. Use the roller up or down arrows to adjust the mechanism to your preferred shoulder height.

Smart tip: To increase intensity in the neck and shoulder region, flip the pillow up so you lay directly on the seat back pad.

TrueFit® Body Scanning



Shoulder Adjustment Icon

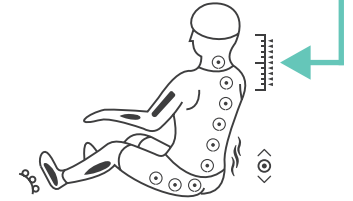

When TrueFit® Body Scanning is running, use the roller up and down arrows to adjust the mechanism to your preferred shoulder height.

Getting Out of the Chair

To easily exit the chair at any time, tap and hold the **POWER** button on the lower bottom of the tablet style controller to restore the chair to the upright position.

WARNING! Check to make sure children and pets are clear of chair **before** pressing power button to return chair to upright position.



Tap and hold the power button to restore the chair to its upright position.

Chair Entry and Exit Hazards

WARNING! The areas under the footrest and behind the back rest are potentially dangerous for a child or pet. The chair back is heavy and reclines with force. A small child or pet located behind the chair could be crushed as chair is reclined resulting in serious injury or death. When chair is reclined, small children or pets who have crawled under the leg rest may not be visible to the user and could be crushed when leg rest is lowered or when chair is returned to upright position. **To avoid serious injury or death, check these areas carefully before reclining, lowering leg rest, or returning chair to upright position.**

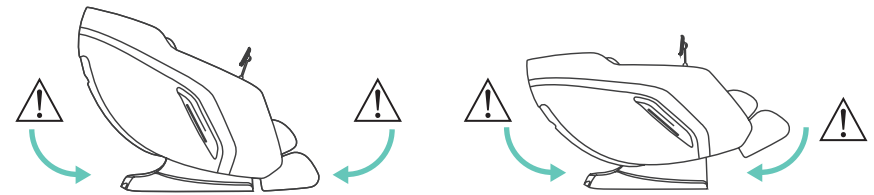

Make sure to check for children or pets **between the chair back and the base of the chair** before entering zero gravity recline.

Make sure to check for children or pets **between the footrest and chair body** before lowering the leg rest.

Make sure to check for children or pets **underneath the footwell** before exiting zero gravity recline and returning to upright position.

Taking Control

Tablet Style Controller



Tablet Style Controller Operations

Button operations defined below.



Power/Play/Pause - Tap the power button to turn on the chair. Tap to pause the chair, tap again to resume. Tap and hold to power down the chair.



Full Body - Offering 6 massage programs called: Full Body, Refreshing, Relaxing, Sport Care, Deep Stretch, and Spine Care. Tap this button to cycle through.



Focused - Offering 3 massage programs called: Neck & Shoulder, Waist & Back, and Glutes. Tap this button to cycle through.



Deep Sleep - Gently soothes the body with slow, rhythmic massage movements designed to calm the mind and prepare you for deep, restorative rest.



All Air - Delivers rhythmic full-body airbag compression therapy that relaxes muscles and improves circulation.



Gentle - Provides a soft, calming massage with light pressure and soothing motions ideal for relaxation and stress relief.



Demo - Tap Demo to start a short program that showcases massage techniques with voice guidance. Tap it again to run the same demo without voice guidance.



Manual Massage - Take full control, offering six targeted techniques—kneading, knocking, clapping, tapping, shiatsu and rolling.



Width - Adjusts how far apart the back rollers move, letting you choose a narrow, medium, or wide stroke across your back.



Speed - Controls how fast the back mechanism moves, giving you six adjustable levels from slow and soothing to fast and invigorating.



Whole - Moves the back mechanism across the entire spine, delivering a full-range massage from your neck to your glutes.



Partial - Narrows the massage area to a smaller section of your spine. Use the roller up/down arrows to move the mechanism to the spot where you want relief.















Point - Precisely targets a single spot for focused, pinpoint relief. Adjust easily using the roller up/down arrows.

Taking Control

Tablet Style Controller Operations (Cont.)

Button operations defined below.

-  **Air Zone** - Tap this button to turn on/off airbag compression therapy. Tap again to cycle through; shoulder, arm, calf, and feet.
-  **Bluetooth/LED** - Bluetooth is enabled by default, tap this button to turn Bluetooth on/off. Tap and hold to turn on/off the Chromotherapy light on the side.
-  **Time** - Adjusts the massage timer by increments of 5 minutes, choose between 10/15/20/25/30 minutes. Once at maximum, tap again to return to 10 minutes.
-  **Air Intensity** - Adjusts the intensity of the airbag compression therapy, tap to cycle through intensity levels.
-  **Voice Broadcasting** - Announces your selected programs, options, and settings through the speakers. Tap to turn on/off.
-  **Heating** - Warms the lower back to relax muscles, improve comfort, and enhance overall massage relief. Tap to turn on/off lumbar heating.
-  **Foot Roller** - Tap to cycle through 3 foot roller intensities; slow, medium, and fast.
-  **Zero-G** - Reclines your body into a weightless position, reducing pressure on the spine and offers 3 levels of recline.
-  **Back Up** - Raises the chair's backrest, allowing you to incline smoothly to find your ideal upright position for comfort. Tap and hold to move continuously.
-  **Back Down** - Lowers the backrest, gently reclining you into a more relaxed, laid-back position. Tap and hold to move continuously.
-  **Roller Up** - Moves the back mechanism higher along your spine to reach your upper back and shoulder area. Tap and hold to move continuously.
-  **Roller Down** - Moves the back mechanism lower along your spine to target your mid- and lower-back areas. Tap and hold to move continuously.

Taking Control

Tablet Style Controller Display Screen

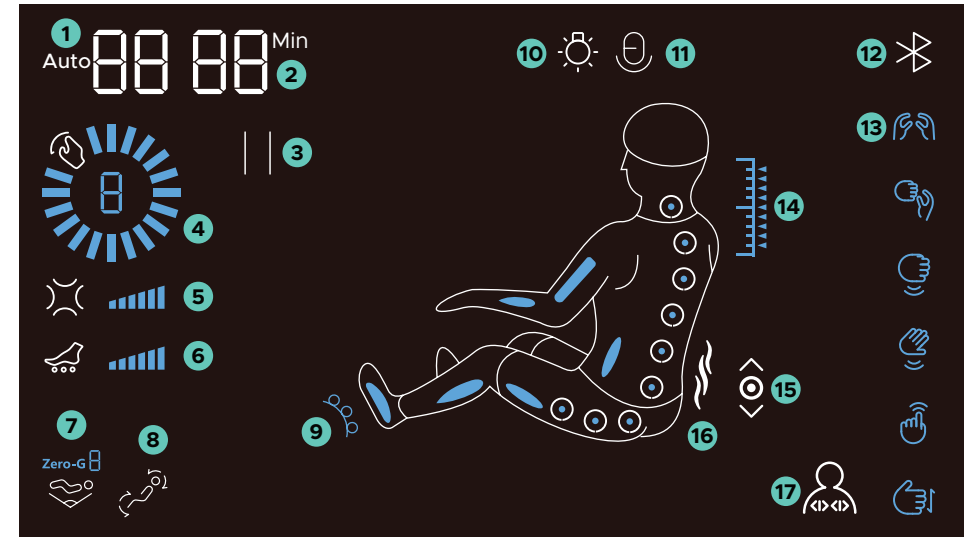

- | | |
|-----------------------------------|--------------------------------|
| 1 Auto Program Number | 9 Foot Roller On/Off |
| 2 Massage Time | 10 Chromotherapy Light |
| 3 Pause | 11 Voice Broadcasting |
| 4 Mechanism Roller Speed | 12 Bluetooth® On/Off |
| 5 Airbag Intensity | 13 Massage Techniques |
| 6 Foot Roller Speed | 14 Shoulder Adjustment |
| 7 Zero Gravity Recline | 15 Mechanism Adjustment |
| 8 Legrest/Backrest Up/Down | 16 Lumbar Heat On/Off |
| | 17 Mechanism Width |

Set your Environment

Auto Mode

On the left hand side of the tablet style controller there is a section called “Auto Mode”. These auto programs offer a great way to jump right into a massage session. There are 6 categories, 3 of these categories have multiple programs to choose from. Starting a program is easy! Start by choosing a category, tap the button multiple times to cycle through available programs.

Example: Tap “Full Body” once to start “Full Body”, tap the category button again to cycle to “Refreshing”, and tap again to start “Relaxing”, tap again for the next program until you restart at the beginning.

Full Body

Full Body - Delivers a head-to-toe experience, combining rollers and air compression to relax muscles, improve circulation, and restore overall comfort.

Refreshing - An uplifting massage with energizing movements that revive muscles and leave you feeling recharged.

Relaxing - Provides slow, soothing motions that melt away tension and calm the body for deep, peaceful comfort.

Sport Care - Targets muscles with stronger, recovery-focused techniques designed to loosen stiffness and promote post-workout relief.

Deep Stretch - Gently elongates the body with slow, controlled traction movements that loosen tight muscles and improve flexibility.

Spine Care - Focuses on the full length of the back, using gentle traction and targeted techniques to align, relax, and support the spine.

Focused

Neck & Shoulder - Targets body tension with focused techniques to relieve tightness in the neck, shoulders, and upper back.

Waist & Back - Targets the mid and lower back with focused motions designed to relieve tension and support core comfort.

Glutes - Targets the hips and glutes with precise pressure to ease muscle tension and enhance overall lower-body comfort.

Deep Sleep

Deep Sleep - Uses slow, calming motions to relax the body and prepare you for deep, restorative rest.

Gentle

Gentle - Delivers soft, soothing movements ideal for light relaxation and stress relief.

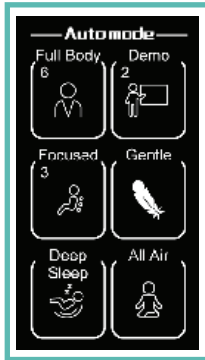

All Air

All Air - Surrounds your body with rhythmic air compression for a soothing, full-body squeeze that relaxes muscles and improves circulation.

Demo

Demo w/ Voice - Provides a quick overview of key techniques with guided voice prompts for easy, hands-free navigation.

Demo w/o Voice - Showcases key techniques in a silent, distraction-free preview of the massage experience.

Manual Mode

Manual mode gives you full control; select your technique, adjust width, speed, and intensity, and target whole, partial, or point areas for precise relief.

Manual Massage

Gives you full control by letting you choose from six techniques: kneading, knocking, clapping, tapping, shiatsu and rolling. So you can customize every move to your exact needs.

Mechanism Width

Adjusts how far apart the rollers move, letting you choose a narrow, medium, or wide back massage. *Note: width can only be changed during knocking, tapping, and shiatsu. See display screen for changes:*



Mechanism Speed

Adjusts the roller movement speed. Tap the button to cycle through six levels, from gentle to vigorous massage intensity.

Whole

Activates full back coverage, allowing the rollers to move from neck to glutes for a complete massage experience.

Partial

Targets a specific area of the back, keeping the rollers focused within a smaller zone for concentrated relief. Use the roller up/down arrows to move the mechanism.

Point

Stops the rollers at a single spot, allowing precise focus on one area for deep, targeted relief. Use the roller up/down arrows to move the mechanism.

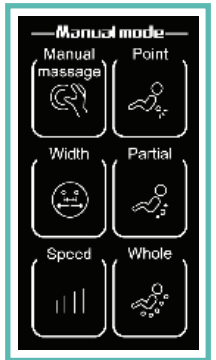

Set your Environment



Power/Play/Pause

Tap the power button to turn on/off the massage chair. Tap pause to temporarily stop the massage session. Tap resume to continue your massage session.

Air Zone

Choose and cycle through upper body, lower body, or whole body for a customized, soothing air compression massage.

Bluetooth/LED

Tap to turn on/off Bluetooth which pairs with any Bluetooth capable device. Tap and hold this button to turn on/off the Chromotherapy light on the side of your chair. **Bluetooth® Pairing:** On your phone or Bluetooth capable device, look for the chair's identity **Zenara**, once selected, a sound will be heard showing that you successfully connected.

Time

Adjust the duration of your massage session, allowing you to cycle through the massage time. Add 5 minute increments; 10/15/20/25/30 minutes, demo will be 6 minutes.

Air Intensity

Controls the strength of the airbag compression. Tap to cycle through levels, from gentle pressure to a firm, invigorating squeeze.

Voice Broadcasting

Audibly announces chair functions and adjustments, keeping you informed of your selections with an audible voice that guides you.

Heating

Gently warms the lumbar area to soothe muscles, promote circulation, and enhance overall relaxation during your massage.

Foot Roller

Massages the soles of your feet which relieves tension, stimulates reflex points, and promotes full-body relaxation. Tap to cycle through intensities; 1 = slow, 2, 3 = fast.

Zero Gravity

Reclines the chair to elevate your legs above your heart, reducing spinal pressure and creating a weightless, deeply relaxing massage experience. Tap to cycle through 3 recline levels.

Back Up

Raises the chair's backrest, allowing you to move from a reclined to a more upright position for comfort or easy exit. Tap and hold to move the backrest continuously.

Back Down

Lowers the chair's backrest, reclining your body into a more relaxed position for a deeper, more soothing massage experience. Tap and hold to move the backrest continuously.

Roller Up

Moves the massage rollers upward along your back, allowing you to adjust their position for targeted relief in higher areas like the neck and shoulders. Tap and hold to move the mechanism.

Roller Down

Moves the massage rollers downward along your back, letting you focus the massage on lower areas such as the lumbar or glutes. Tap and hold to move the mechanism.

Staying Safe

SAFETY INFORMATION

To ensure safe use of the massage chair and avoid injury or unsafe conditions, please read and follow all instructions before using product. **SAVE THESE INSTRUCTIONS.**

⚠ WARNING

- Never use pins or other metallic fasteners with this appliance.
- Carefully examine the covering before each use. Discard the appliance if the covering shows any sign of deterioration, such as checking, blistering, or cracking.
- An appliance should never be left unattended when plugged in. Unplug from outlet when not in use, and before putting on or taking off parts.
- Do not operate where aerosol (spray) products are being used or where oxygen is being administered.
- To disconnect, turn all controls to the off position, then remove plug from outlet. Temperatures sufficiently high to cause burns may occur regardless of the control setting.
- Do not use on an infant or invalid or on a sleeping or unconscious person. Do not use on insensitive skin or on a person with poor blood circulation. Check the skin in contact with the heated area of the appliance frequently to reduce the risk of blistering.
- Do Not Crush – Avoid sharp folds.

⚠ WARNING

USE NOT RECOMMENDED FOR CERTAIN PERSONS

Use of massage chair may not be safe or suitable for persons with certain medical conditions and could cause serious injury or death in some circumstances. If you have any of the following conditions, please consult a physician before using the massage chair:

- | | |
|---|---|
| - Use of implanted electronic medical devices (such as a cardiac pacemaker) | - Implanted medical fixation devices such as rods, pins, etc. |
| - Pregnancy | - Recent surgery or sutures |
| - Cancer, malignant tumors, or other growths | - Skin diseases or skin injury |
| - Osteoporosis or spinal fracture | - High fever |
| - Other fractures or musculoskeletal injuries | - Certain pulmonary or breathing conditions |
| - Loss of or reduced sensitivity to heat | - Impaired circulation |

⚠ WARNING

The areas under the footrest and behind the back rest are potentially dangerous for a child or pet. The chair back is heavy and reclines with force. A small child or pet located behind the chair could be crushed as chair is reclined resulting in serious injury or death. When chair is reclined, small children or pets who have crawled under the leg rest may not be visible to the user and could be crushed when leg rest is lowered or when chair is returned to upright position. To avoid serious injury or death, check these areas carefully before reclining, lowering leg rest, or returning chair to upright position.

⚠ CAUTION

CAUTION

To avoid the risk of minor injury or discomfort, or damage to the massage chair or other property, please read and follow these instructions for safe use of massage chair:

- Do not stand or stack heavy objects on footrest.
- Do not operate heating features of chair while under a blanket or pillow. Excessive heating can occur and cause fire, electric shock, or injury to persons.
- To avoid pinching or crushing, please do not place body parts, especially fingers and toes, between parts of chair and keep clear of moving parts.
- To avoid overheating, injury or discomfort from overuse, do not fall asleep while using massage chair and do not use for extended periods of time (longer than 20 minutes).
- Avoid use while under the influence of alcohol, medications or other substances that may cause drowsiness, disorientation, or impairment of judgment or motor skills.
- Do not use the massage chair right after a meal, as it may cause discomfort.
- If you feel any abnormal discomfort during the operation of the massage chair, turn off the power immediately and discontinue use.
- Do not use this appliance when ambient temperature is over 40 C (104 F).
- Do not use this appliance in humid or dusty environment, or when any part of the body is in contact with plumbing or any similar ground.
- Never operate the appliance with the air openings blocked. Keep the air openings free of lint, hair, dust and the like.
- Do not use outdoors.
- Do not operate where aerosol (spray) products are being used or where oxygen is being administered.
- Place the product on a flat, level floor to reduce risk of tipping or overturning.
- Do not use or store near heat or open flame.
- Intended only for users who weigh below 300 lbs.
- Use this product only for its intended use as described in this manual. Do not use attachments not recommended by the manufacturer.
- Massage chair intended only for use by one person. Do not use by two or more persons at the same time to avoid damage to the product.
- Do not allow children to stand, jump, or play on or around massage chair, even when it is not powered on or in use.
- Remove personal accessories such as jewelry from arms and empty pockets, and remove loose clothing while using the massage features of the chair.
- Check the upholstery under the cushions and other spots for damage or loose objects that may cause injury or damage chair while operating. If any damage is present, do not use the massage chair and refer to a qualified service professional for servicing.
- To avoid damage to chair, walls, or other objects, make sure there are no obstacles behind the chair and there is enough clearance before adjusting the backrest or leg rest angle.
- Please be seated properly while using the product.
- To avoid damage to chair or floors, do not drag or push the chair or roll its casters on wood floor or carpet. See instructions on p.6 for safely moving chair.
- If massage chair is not working properly, has been dropped or damaged, or has been dropped into water or exposed to flooding, return the appliance to a service center for examination and repair before attempting to use.
- Do not drop or insert any object into any openings in chair.

WARNING

Read and follow these instructions concerning safe use of the power cord and power unit to avoid possible electric shock, fire hazard, use of chair by and injury to unattended children, or damage to chair or other property.

WARNING

- To avoid risk of electric shock, connect this unit to a properly grounded outlet only. See Grounding Instructions on pg. 7.
- Always unplug massage chair from the electrical outlet immediately after use and before cleaning. An appliance should never be left unattended when plugged in. To disconnect, turn all controls to the off position, then remove plug from outlet.
- Do not use massage chair and unplug from outlet during thunder or lightning storms, and before putting on or taking off parts.
- To ensure safe operation, power must be supplied only at standard 110 voltage, to the specifications of the appliance. Confirm that the power voltage stated on the rating label corresponds to your local electricity supply.
- The massage chair should be used only with the power supply unit provided. Do not use with any other power source.
- Do not use a wet or damp hand to unplug the cord to avoid electric shock.
- Do not pull on the power cord to unplug. Grip by plastic end nearest outlet to unplug power cord.
- Do not squeeze, over bend, pull hard, or twist the power cord.
- Keep the power cord away from heated surfaces.
- Do not carry or drag the chair by power cord or use cord as a handle.
- If there is any smoke or unusual smell while using massage chair, stop using immediately and unplug the power cord.
- Never operate the chair if it has a damaged power cord or plug. If the power cord is damaged, it must be replaced by the manufacturer or its service agent or a similarly qualified person to avoid a hazard.

Do not disassemble, dismantle or attempt to repair massage chair. Such actions, as well as misuse of product, may cause damage to or failure of massage chair and may void the manufacturer's warranty. For repairs, please contact an authorized dealer or repair agent at 603-910-5000. For additional details concerning terms, conditions and limitations of warranty, see <https://infinitymassagechairs.com/warranty-info>.

Fixing Issues

Troubleshooting

No.	Symptoms	Possible Causes	Possible Solutions
1	Noise is heard while in use	These noises are normal and arise from friction between the massage rollers and the faux leather cover	No need to take any measures
2	Massage Chair does not start	- The power cord is not secured into the socket - Not switched ON	- Insert the power plug properly into the power socket - Turn on power switch, then press the power button
3	No audio comes from the speaker	The devices are not paired together	Make sure Bluetooth and phone are both ON
4	Backrest or footrest can not raise or recline	Excessive load has been pressed on the backrest/legrest	Reduce the load and try again
5	Airbag malfunction	The air hose is blocked	Straighten the air hose and clearout the blockage

If the problem remains, please contact Infinity for maintenance.

Tip: Do not attempt to repair this product yourself, our company shall not be liable for the injury or damage caused by any servicing without authorizations. Thank you for your cooperation

Specifications

Model	Zenara™
Dimension of Main Body (in)	58"x29.7"x44.5" (LxWxH)
Necessary Clearance to Wall (in)	9.5"
Net Weight (lbs)	147.71
Shipping Weight (lbs)	196.21
Max. User Weight (lbs)	300
Voltage	100-240V~
Rated Current	0.4A-0.9A
Power Consumption	90W

Fixing Issues

Frequently Asked Questions

Q: I find the chair is too intense to be comfortable. What can I do?

A: Your body needs to become acclimated to therapeutic massage. To be effective, the massage techniques must compress the tissue in your body. We recommend the following steps to help get started. Then over time as your body acclimates you can increase the intensity by reducing the layers between you and the chair.

1. Use Pillow to reduce upper body intensity.
2. Tap **Air Intensity** to reduce the intensity of the airbags.
3. Tap **Air Region** to cycle through the amount of airbags on your body.
4. Adjust the recline on the tablet style controller. More upright will be less intense. Zero Gravity Recline will be more intense.
5. If after adjustments and attempt to acclimate, you still experience discomfort, discontinue use and consult a physician.

Q: I'm not a foot massage person, what should I do?

A: Turn off the Foot Reflexology Roller. While in auto program or manual massage mode tap the foot roller until the setting is off, this will help alleviate pressure on the foot region.

Q: My chair is not performing as expected. What should I do?

A: Your Infinity massage chair is an amazing combination of programming and robotics. On occasion the chair just may need to be rebooted. To do this power down the chair and unplug from the wall for 5 minutes then plug back in and power back up to see if it self-healed. If you are still having an issue, give Infinity a call at 603-910-5000.

Q: I can never seem to get in my Infinity Massage chair, someone is always in it.

A: We know. It happens. Tell your friends to get their own Infinity Chair.

For more information and access to further questions, and resources, visit our website at www.infinitymassagechairs.com

Warranty

This Infinity Massage Chairs is protected by Infinity's 5 Year U.S Residential Limited Warranty. For more information, scan the QR code below and click on the **Infinity Care Residential Warranty** tab.



INFINITY[®]

72 Stard Road, Seabrook, NH 03874
603-910-5000
www.infinitymassagechairs.com

Version 1.2